



Please write clearly in block capitals.

Centre number

--	--	--	--	--

Candidate number

--	--	--	--

Surname

\_\_\_\_\_

Forename(s)

\_\_\_\_\_

Candidate signature

\_\_\_\_\_

I declare this is my own work.

# GCSE CHEMISTRY

# H

Higher Tier Paper 1

Monday 19 May 2025 Morning Time allowed: 1 hour 45 minutes

## Materials

For this paper you must have:

- a ruler
- a scientific calculator
- the periodic table (enclosed).

## Instructions

- Use black ink or black ball-point pen.
- Pencil should only be used for drawing.
- Fill in the boxes at the top of this page.
- Answer **all** questions in the spaces provided. Do not write outside the box around each page or on blank pages.
- If you need extra space for your answer(s), use the lined pages at the end of this book. Write the question number against your answer(s).
- Do all rough work in this book. Cross through any work you do not want to be marked.

## Information

- The maximum mark for this paper is 100.
- The marks for questions are shown in brackets.
- You are expected to use a calculator where appropriate.
- In all calculations, show clearly how you work out your answer.
- You are reminded of the need for good English and clear presentation in your answers.

For Examiner's Use	
Question	Mark
1	
2	
3	
4	
5	
6	
7	
8	
9	
<b>TOTAL</b>	



JUN2584621H01

IB/M/Jun25/G4007/E11

8462/1H

**0 1**

This question is about elements in the periodic table.

**0 1 . 1**

Describe where the non-metallic elements are found in the periodic table.

**[1 mark]**

---

---

**0 1 . 2**

Gallium (Ga) is a metallic element in Group 3.

Which of these properties of gallium is **not** typical of most metals?**[1 mark]**Tick (✓) **one** box.

A boiling point above 1000 °C

A melting point below 100 °C

Conducts electricity when solid

Forms positive ions



0 1 . 3 A sodium atom can be represented as  ${}_{11}^{23}\text{Na}$

Complete **Figure 1** to show the electronic structure of a sodium atom.

[1 mark]

**Figure 1**

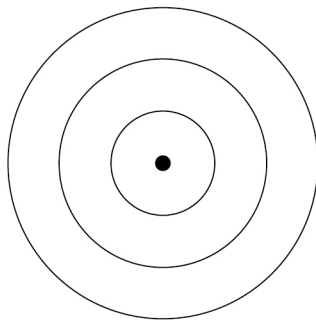

0 1 . 4 Mendeleev created an early periodic table.

Mendeleev placed most of the elements in order of atomic weight.

Tellurium and iodine were not placed in order of atomic weight.

Why did Mendeleev **not** place tellurium and iodine in order of atomic weight?

[1 mark]

---



---

0 1 . 5 Argon is an element in Group 0 of the periodic table.

Explain why argon is unreactive.

[2 marks]

---



---



---



---

Turn over ►



An element **X** consists of two isotopes.

**0 1 . 6** What is meant by 'isotopes'?

Answer in terms of subatomic particles.

**[2 marks]**

---



---



---



---

**0 1 . 7** **Table 1** shows the mass numbers and percentage abundances of the isotopes of **X**.

**Table 1**

Mass number	Percentage abundance (%)
113	4
115	96

Which is the closest estimate to the relative atomic mass of **X**?

**[1 mark]**

Tick (✓) **one** box.

~113       ~114       ~115

**9**



**0 2**

This question is about structure and bonding.

Calcium sulfide is an ionic compound.

**Figure 2** represents the structure of calcium sulfide.

**Figure 2**

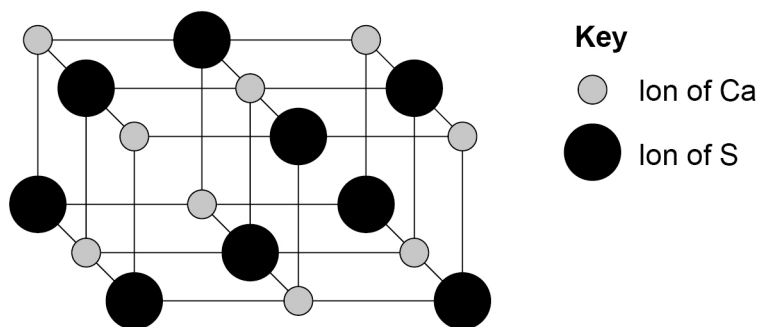
**0 2 . 1**

Determine the empirical formula of calcium sulfide.

**[1 mark]**

Empirical formula \_\_\_\_\_

**Question 2 continues on the next page**

**Turn over ►**



0 2 . 2 Calcium is in Group 2 of the periodic table.

Sulfur is in Group 6 of the periodic table.

Describe what happens when a calcium atom reacts with a sulfur atom.

Answer in terms of electrons and ions.

**[4 marks]**

---

---

---

---

---

---

---

---

---

---



Figure 3 shows the structure of graphite.

Figure 3

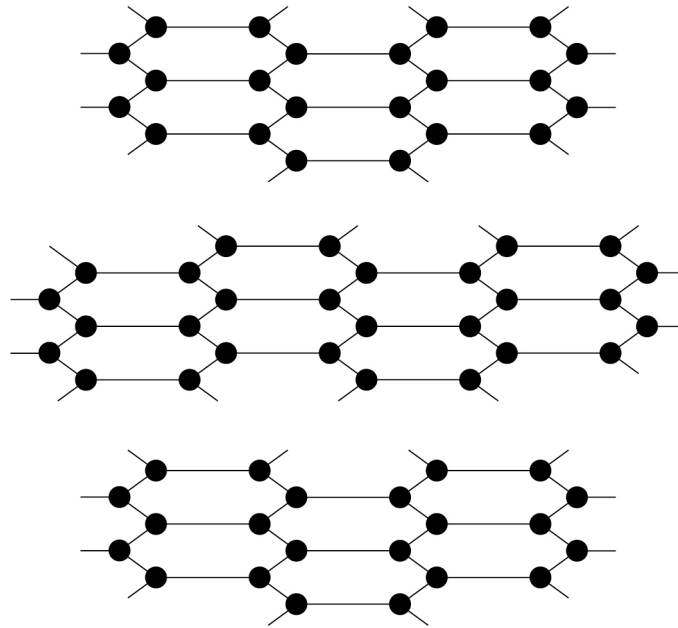

Key

● Carbon atom

0 2 3

Describe the structure and bonding of graphite.

[4 marks]

---



---



---



---



---



---



---



---



---

Extra space

---

Turn over ►



**0 2 . 4** Substances that consist of small molecules do **not** conduct electricity.

Give **one** reason why.

[1 mark]

---

---

**0 2 . 5** Methane consists of small molecules.

Poly(ethene) is a polymer.

Why does poly(ethene) have a higher melting point than methane?

[1 mark]

Tick (✓) **one** box.

Poly(ethene) has more covalent bonds to break than methane.

Poly(ethene) has no intermolecular forces to overcome.

Poly(ethene) has stronger covalent bonds to break than methane.

Poly(ethene) has stronger intermolecular forces to overcome than methane.

      
**11**



**0 3**

This question is about metals and metal oxides.

Tin (Sn) is extracted from tin oxide using carbon.

The equation for the reaction is:

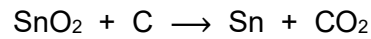
**0 3 . 1**

Which substance is reduced in this reaction?

Give **one** reason for your answer.

Answer in terms of oxygen.

**[2 marks]**

Substance reduced \_\_\_\_\_

Reason \_\_\_\_\_

\_\_\_\_\_

**0 3 . 2**

Why can carbon be used to extract tin from tin oxide?

**[1 mark]**

\_\_\_\_\_

\_\_\_\_\_

**Question 3 continues on the next page**

**Turn over ►**

**0 3 . 3** Cadmium (Cd) can be extracted by the reaction of cadmium oxide with carbon.

The equation for the reaction is:

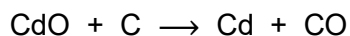

Calculate the percentage atom economy for the production of cadmium in this reaction.

Relative atomic masses ( $A_r$ ): C = 12 Cd = 112

Relative formula mass ( $M_r$ ): CdO = 128

**[3 marks]**

---

---

---

---

---

Percentage atom economy = \_\_\_\_\_ %

**0 3 . 4** Tungsten is a transition metal.

Potassium is a Group 1 metal.

Give **two** differences between the properties of tungsten and the properties of potassium.

**[2 marks]**

1 \_\_\_\_\_

---

2 \_\_\_\_\_

---



Tungsten oxide reacts with hydrogen to give tungsten (W) and water.

**0 3 . 5** The equation for the reaction is:

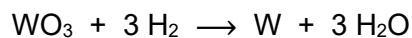

The law of conservation of mass states:

‘The mass of the products equals the mass of the reactants during a chemical reaction.’

Show that the equation obeys the law of conservation of mass.

Relative atomic mass ( $A_r$ ): W = 184

Relative formula masses ( $M_r$ ): H<sub>2</sub> = 2    WO<sub>3</sub> = 232    H<sub>2</sub>O = 18

**[2 marks]**

---



---



---



---

**0 3 . 6** The reaction producing tungsten has a high atom economy.

Why is it important to use reactions with a high atom economy in industry?

**[1 mark]**

---



---



0 4

The elements in Group 7 of the periodic table are known as the halogens.

Figure 4 shows information about some of the elements in Group 7.

Figure 4

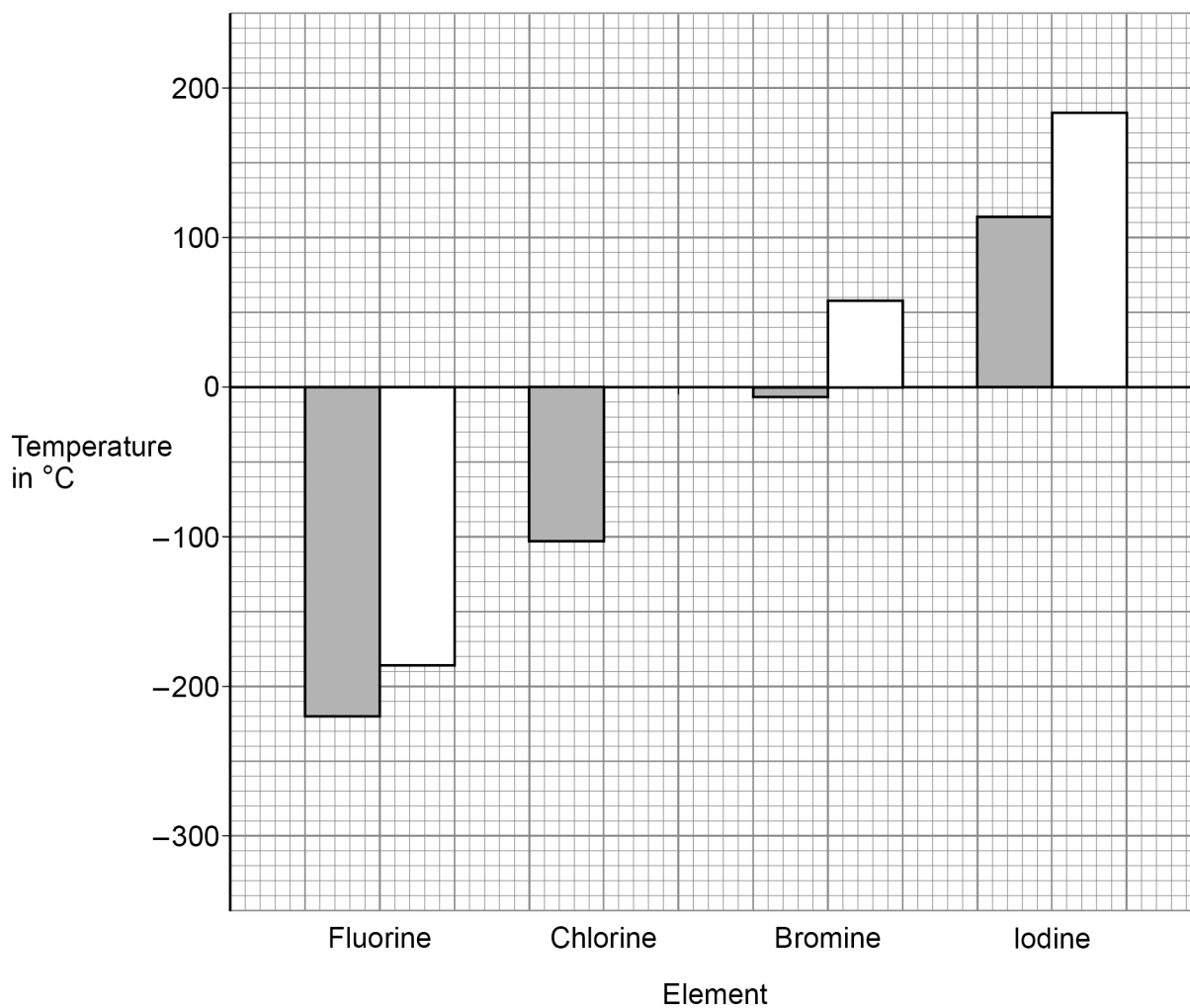

Key:  Melting point  
 Boiling point



**0 4 . 1** Predict the boiling point of chlorine.

Use **Figure 4**.

[1 mark]

\_\_\_\_\_ °C

**0 4 . 2** What is the state of fluorine at  $-250\text{ }^{\circ}\text{C}$ ?

Use **Figure 4**.

[1 mark]

\_\_\_\_\_

Astatine (At) is an element in Group 7.

**0 4 . 3** What is the number of electrons in the outer shell of an astatine atom?

[1 mark]

\_\_\_\_\_

**0 4 . 4** Hydrogen reacts with astatine to produce hydrogen astatide.

Predict the formula of hydrogen astatide.

[1 mark]

\_\_\_\_\_

**Question 4 continues on the next page**

**Turn over ►**



0 4 . 5

Explain the trend in reactivity of the elements going down Group 7.

**[4 marks]**

---

---

---

---

---

---

---

---

---

---

Extra space 

---

---

0 4 . 6

A more reactive halogen can displace a less reactive halogen from a solution of its salt.

Write a balanced equation for the reaction between bromine and potassium iodide.

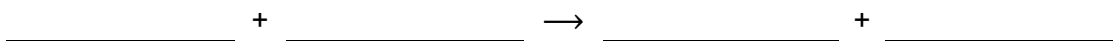
**[3 marks]**

---

11

**0 5**

This question is about small particles.

Before the discovery of the electron, atoms were thought to be tiny spheres that could not be divided.

**0 5 . 1**

The discovery of the electron led to the plum pudding model of the atom.

Describe the plum pudding model of the atom.

**[2 marks]**

---

---

---

---

**0 5 . 2**

The model of the atom changed again after the alpha particle scattering experiment.

Give **two** conclusions that were made from the alpha particle scattering experiment.

**[2 marks]**

1 \_\_\_\_\_

---

2 \_\_\_\_\_

---

**0 5 . 3**

Niels Bohr made another change to the model of the atom.

What was this change?

**[1 mark]**

---

---

**Turn over ►**

**0 5 . 4** A helium atom has a radius of  $1.4 \times 10^{-10}$  m.

The nucleus of this atom has a radius of  $1.7 \times 10^{-15}$  m.

How many times larger is the radius of the atom than the radius of the nucleus?

**[1 mark]**

Tick (✓) **one** box.

~1000 times larger

~10 000 times larger

~100 000 times larger

~1 000 000 times larger



Nanoparticles contain a few hundred atoms.

**0 5 . 5** Figure 5 represents a cubic nanoparticle.

**Figure 5**

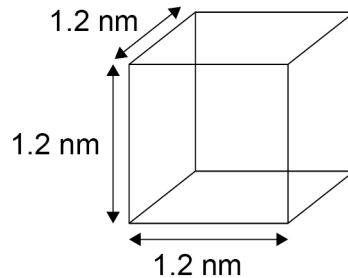

Calculate the simplest surface area : volume ratio of the cubic nanoparticle.

**[4 marks]**

---



---



---



---



---

Simplest surface area to volume ratio = \_\_\_\_\_ :

**0 5 . 6** Lenses in reading glasses often have a scratch-resistant coating that contains a hard substance.

Nanoparticles of the hard substance are used instead of fine particles of the hard substance.

Explain why nanoparticles are used instead of fine particles.

**[2 marks]**

---



---



---



---



**0 6**

Aluminium is extracted by the electrolysis of a molten mixture.

The mixture contains aluminium oxide and one other substance.

**0 6 . 1**

Aluminium oxide is an ionic compound.

Explain why aluminium oxide has a very high melting point.

**[4 marks]**

---

---

---

---

---

---

---

---

---

---

Extra space

---

---

**0 6 . 2**

Name the substance added to aluminium oxide to form the mixture.

**[1 mark]**

---

**0 6 . 3**

Give **one** reason why a mixture is used as the electrolyte.

**[1 mark]**

---

---



Oxygen is produced at the positive electrode.

**0 6 . 4** Write the half equation for the reaction that produces oxygen at the positive electrode. **[2 marks]**

\_\_\_\_\_ → \_\_\_\_\_ + \_\_\_\_\_

**0 6 . 5** The positive electrode must be continually replaced.

Explain why.

**[3 marks]**

\_\_\_\_\_

\_\_\_\_\_

\_\_\_\_\_

\_\_\_\_\_

\_\_\_\_\_

\_\_\_\_\_

11

**Turn over for the next question**

**Turn over ►**



0 7

Hydrazine ( $\text{N}_2\text{H}_4$ ) is a compound of nitrogen and hydrogen.

0 7 . 1

Scientists are researching the use of hydrazine in fuel cells.

**Table 2** gives some information about the use of hydrogen and hydrazine in fuel cells.

**Table 2**

	Hydrogen	Hydrazine
State at room temperature	Gas	Liquid
Hazards	Explosive	Toxic
Equation for fuel cell reaction	$2 \text{H}_2 + \text{O}_2 \rightarrow 2 \text{H}_2\text{O}$	$\text{N}_2\text{H}_4 + \text{O}_2 \rightarrow \text{N}_2 + 2 \text{H}_2\text{O}$
Voltage produced in volts	1.23	1.61
Catalyst needed for reaction	Platinum	None

Evaluate the use of hydrazine instead of hydrogen in a fuel cell.

**[4 marks]**

---



---



---



---



---



---



---



---

Extra space \_\_\_\_\_

---



**Figure 6** shows a model of the hydrazine molecule.

**Figure 6**

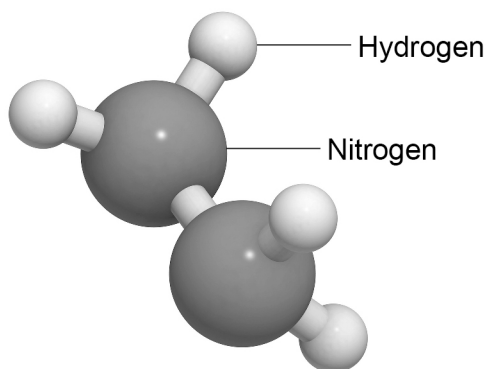

**0 7 . 2** Complete the dot and cross diagram for hydrazine in **Figure 7**.

Show the outer shell electrons only.

**[2 marks]**

**Figure 7**

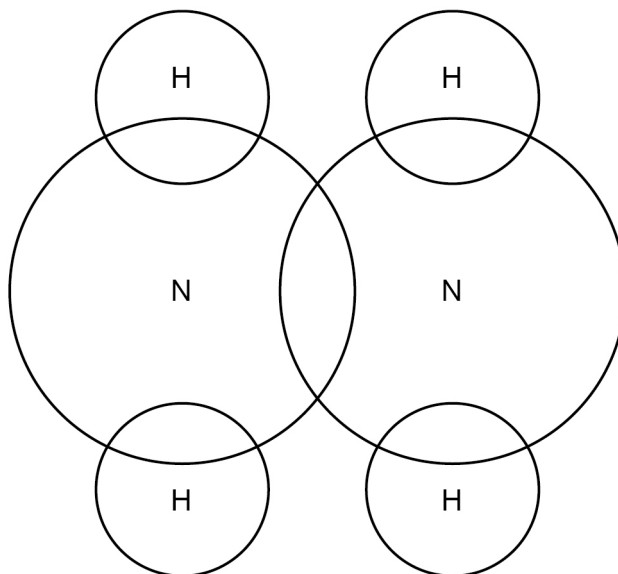

**0 7 . 3** Give **one** advantage of the ball and stick model in **Figure 6** compared to the dot and cross diagram.

**[1 mark]**

---



---

Turn over ►



0 7 . 4

**Figure 8** shows the displayed formula equation for the reaction of hydrazine with oxygen.

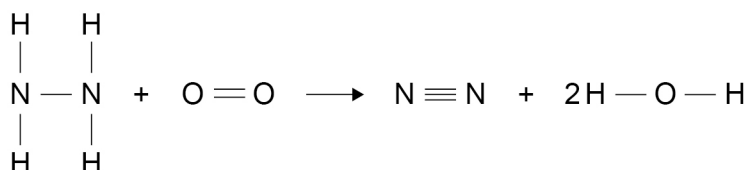
**Figure 8**

The reaction is exothermic.

The energy released forming new bonds is 581 kJ/mol greater than the energy needed to break existing bonds.

**Table 3** shows some bond energies.

**Table 3**

<b>Bond</b>	N — N	N — H	O = O	N ≡ N	O — H
<b>Bond energy in kJ/mol</b>	<b>X</b>	391	498	945	464

Calculate the bond energy (**X**) of the N — N bond.

**[4 marks]**

---



---



---



---



---



---



---



---

**X** = \_\_\_\_\_ kJ/mol

11
----



**0 8**

This question is about alkalis and acids.

**0 8 . 1**What is the formula of the ion that **all** alkalis contain when in solution?**[1 mark]**

---

A student planned a titration experiment to determine the concentration of a sodium hydroxide solution.

This is the student's plan.

1. Measure 25.0 cm<sup>3</sup> of sulfuric acid of known concentration using a pipette.
2. Add the sulfuric acid to a conical flask.
3. Add 3 drops of universal indicator to the conical flask.
4. Place the conical flask on a white tile.
5. Fill a burette with sodium hydroxide solution to the 0.00 cm<sup>3</sup> mark.
6. Add sodium hydroxide solution to the conical flask and swirl the flask.
7. Stop adding sodium hydroxide solution when there is a colour change.
8. Record the volume of sodium hydroxide solution used.
9. Repeat steps 1 to 8 until consistent results are obtained.

**0 8 . 2**Suggest **two** improvements to the plan.Give **one** reason for each improvement.**[4 marks]**

Improvement 1 \_\_\_\_\_

---

Reason \_\_\_\_\_

---

Improvement 2 \_\_\_\_\_

---

Reason \_\_\_\_\_

---

**Turn over ►**

0 8 . 3 Figure 9 shows the burette after one titration.

Figure 9

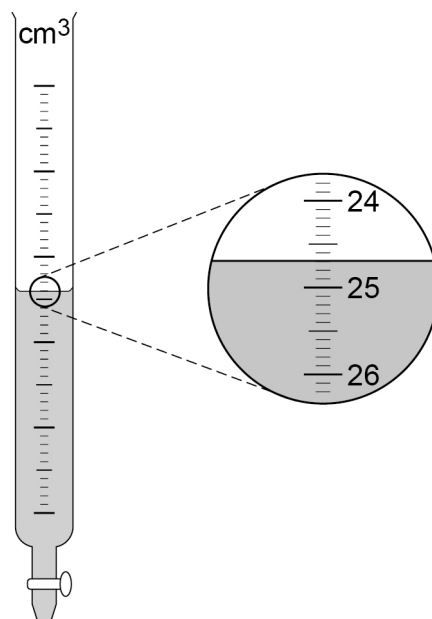

What is the reading on the burette?

[1 mark]

\_\_\_\_\_ cm<sup>3</sup>



**0 8 . 4**

In a different titration, 25.0 cm<sup>3</sup> of 0.216 mol/dm<sup>3</sup> sulfuric acid needed 11.25 cm<sup>3</sup> of sodium hydroxide solution for neutralisation.

The equation for the reaction is:

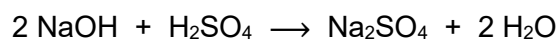

Calculate the concentration of the sodium hydroxide solution.

**[4 marks]**

---

---

---

---

---

---

---

---

Concentration = \_\_\_\_\_ mol/dm<sup>3</sup>

**Question 8 continues on the next page**

**Turn over ►**

**Table 4** gives information about solutions of two acids.

**Table 4**

Formula of acid	Concentration of solution in mol/dm <sup>3</sup>	Percentage (%) of acid molecules that are ionised
HCl	0.1	100
HCN	2.0	0.01

**0 8 . 5** Which is a correct statement about the solutions of HCl and HCN in **Table 4**?

**[1 mark]**

Tick (✓) **one** box.

The HCl is a more concentrated and stronger acid than the HCN.

The HCl is a more concentrated and weaker acid than the HCN.

The HCl is a more dilute and stronger acid than the HCN.

The HCl is a more dilute and weaker acid than the HCN.

**0 8 . 6** In **Table 4**, the solution of HCl has a lower pH than the solution of HCN.

Explain why.

Use the data in **Table 4**.

**[2 marks]**

---



---



---



---







**There are no questions printed on this page**

*Do not write  
outside the  
box*

**DO NOT WRITE ON THIS PAGE  
ANSWER IN THE SPACES PROVIDED**







